

(No Model.)

3 Sheets—Sheet 1.

S. SLAYTON.

LATHE.

No. 367,246.

Patented July 26, 1887.

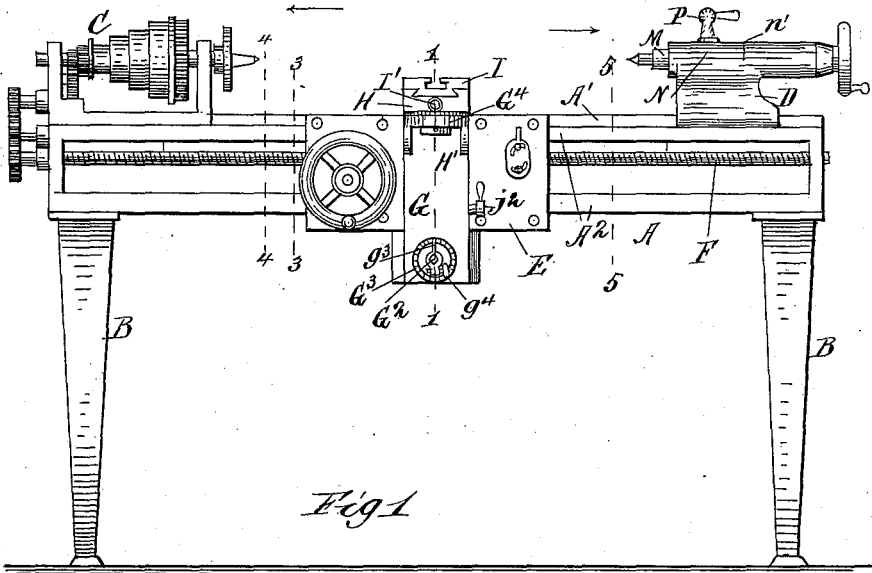

Fig 1

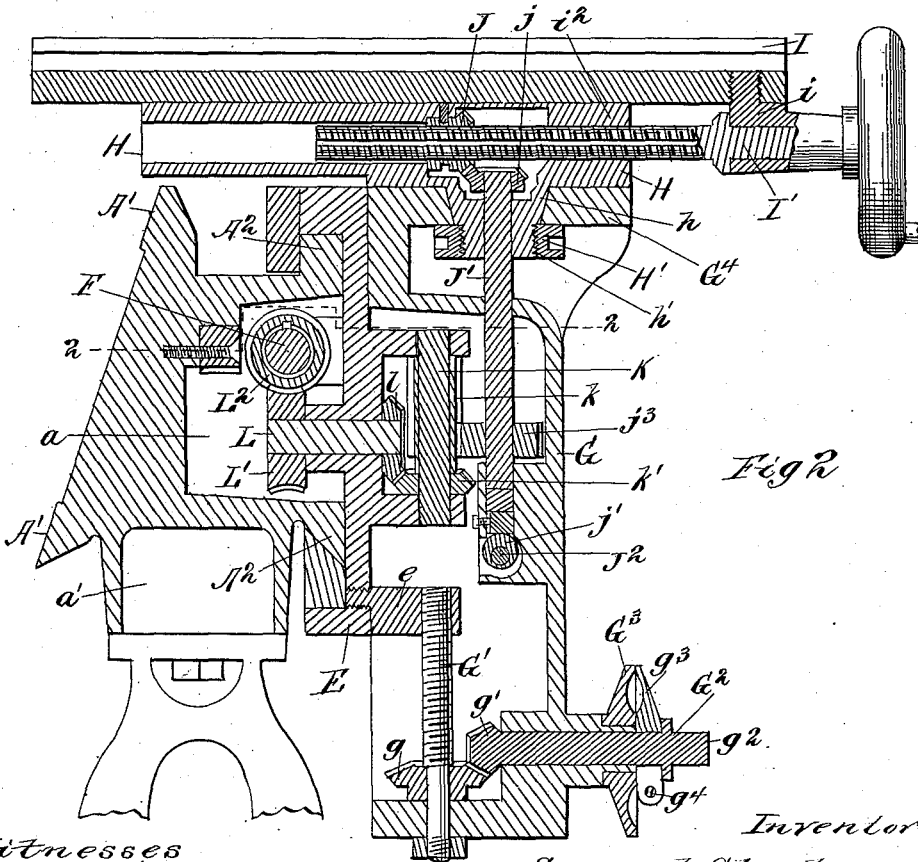

Fig 2

Witnesses
W. C. Coates
A. M. Best.

Inventor
Samuel Slayton
Osborn T. Fracker
 Attorneys

BY

S. SLAYTON.
LATHE.

No. 367,246.

Patented July 26, 1887.

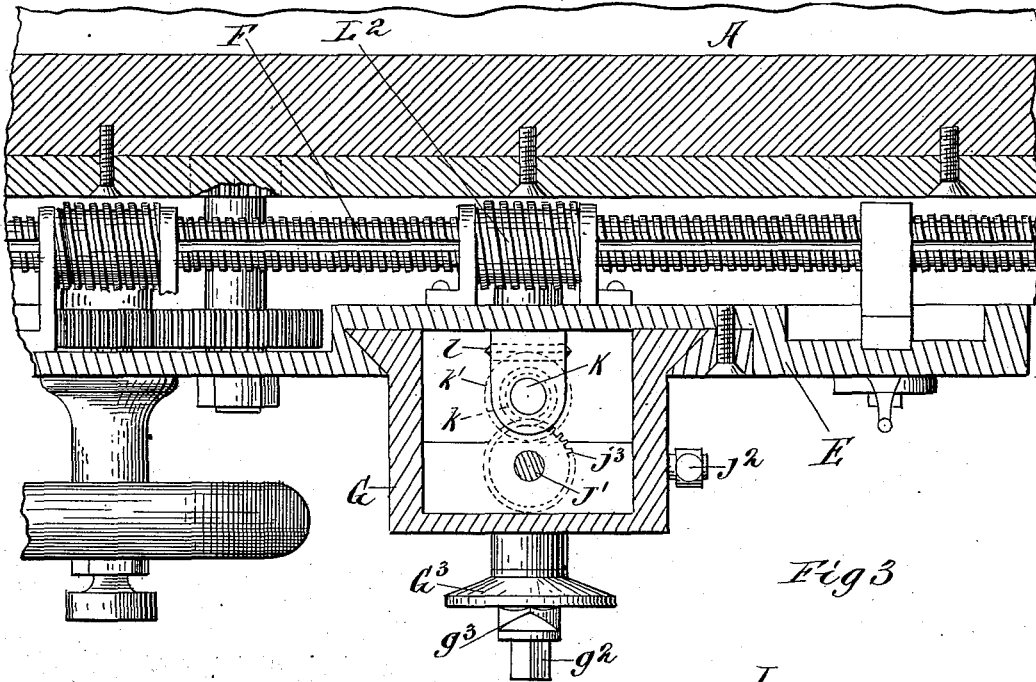

Fig 3

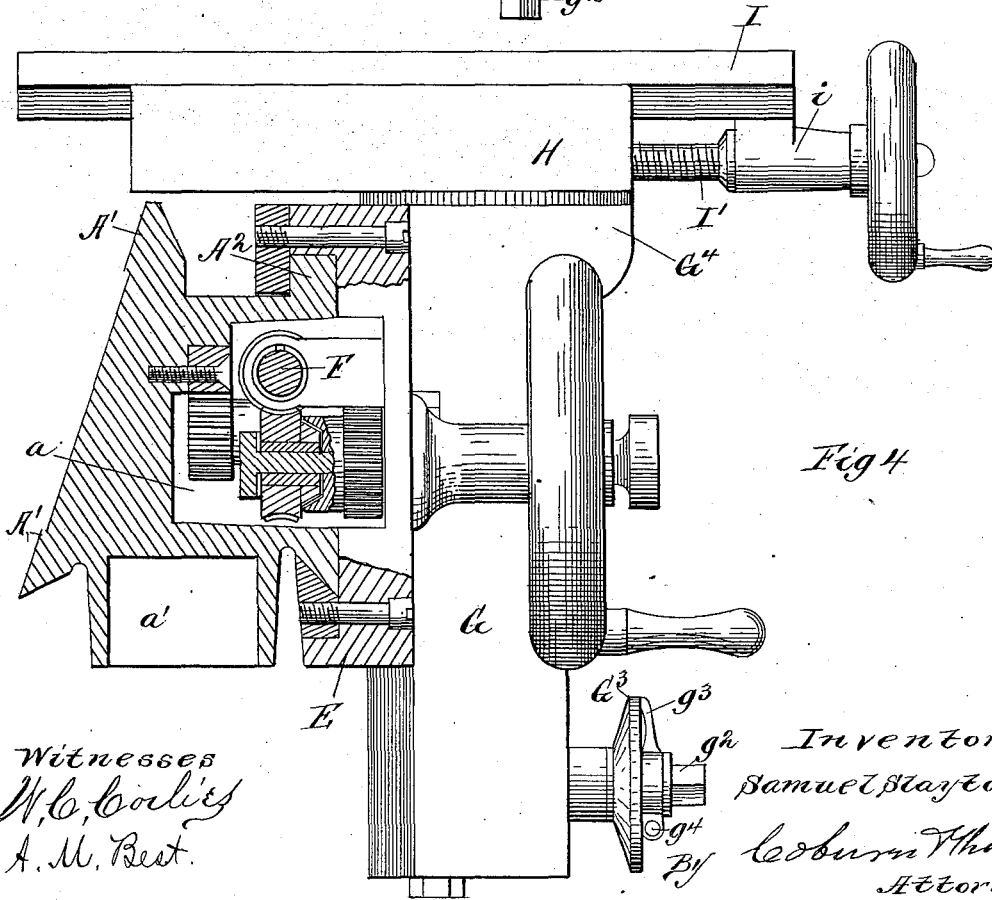

Fig 4

Witnesses
W. C. Corlies
A. M. Best.

Inventor
Samuel Slayton
By Leburn Thacker
Attorneys

(No Model.)

3 Sheets—Sheet 3.

S. SLAYTON.

LATHE.

No. 367,246.

Patented July 26, 1887.

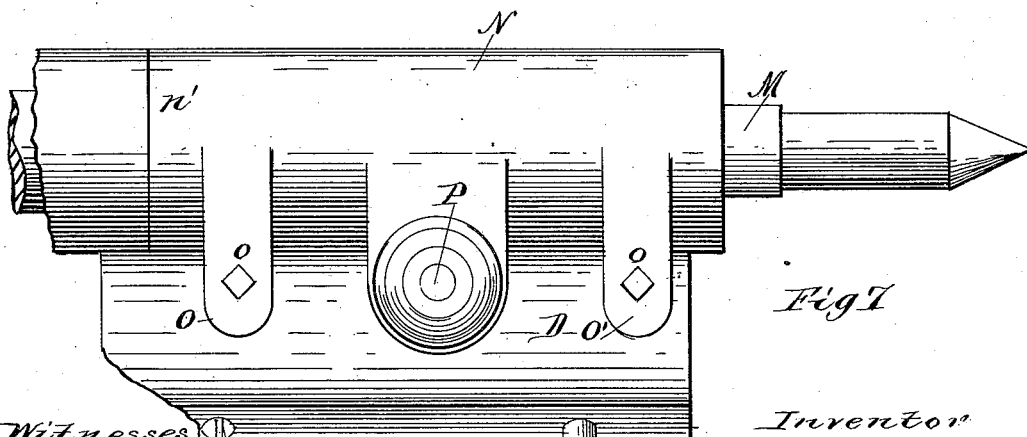
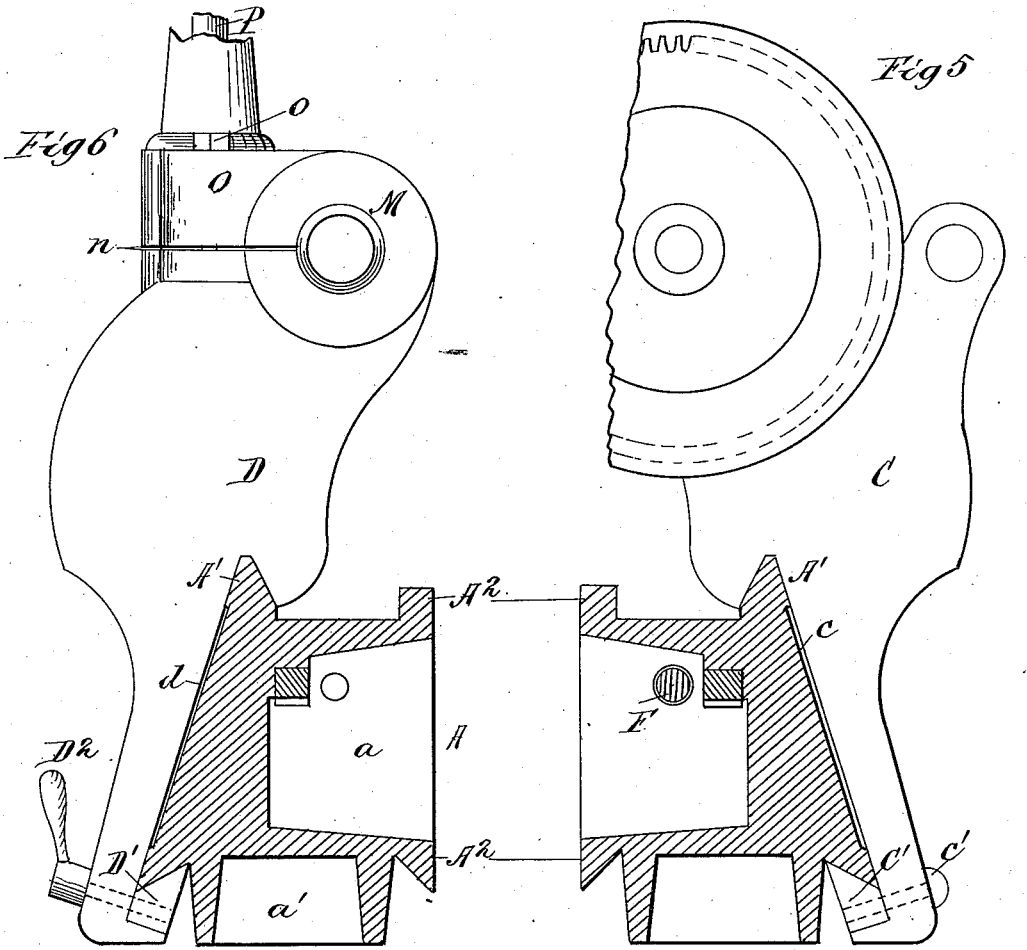

Witnesses
W. C. Collier
A. M. Best

Inventor
Samuel Slayton
 By *Edburn Thacher*
 Attorneys

UNITED STATES PATENT OFFICE.

SAMUEL SLAYTON, OF CHICAGO, ILLINOIS, ASSIGNOR TO ALBERT M. BILLINGS, OF SAME PLACE.

LATHE.

SPECIFICATION forming part of Letters Patent No. 367,246, dated July 26, 1887.

Application filed March 5, 1887. Serial No. 229,873. (No model.)

To all whom it may concern:

Be it known that I, SAMUEL SLAYTON, a citizen of the United States, residing at Chicago, in the county of Cook and State of Illinois, have invented a certain new and useful Improvement in Lathes, which is fully set forth in the following specification, reference being had to the accompanying drawings, in which—

Figure 1 is an elevation of a lathe embodying my invention; Fig. 2, a sectional view of the same taken on the line 1 1 of Fig. 1; Fig. 3, a plan section taken on the line 2 2 of Fig. 2; Fig. 4, a sectional view taken on the line 3 3 of Fig. 1; Fig. 5, a sectional view taken on the line 4 4 of Fig. 1, and looking in the direction of the arrow; Fig. 6, a sectional view taken on the line 5 5 of Fig. 1, and looking in the direction of the arrow, and Fig. 7 a detail plan view of the tail-stock detached.

Like letters refer to like parts in all the figures of the drawings.

My invention relates to lathes, and has for its object to produce a lathe containing various improved features, by means of which the effectiveness, durability, and practical operation of the same shall be improved; and to these ends my invention consists in certain novel features, which I will now proceed to describe, and will then particularly point out in the claims.

In the drawings, A represents the bed of the lathe, which is mounted on suitable legs or supports, B, firmly attached to each end thereof. Upon its rear side this bed is provided with a suitable way, A', having beveled or undercut edges to receive the head-stock and tail-stock, which are mounted upon said way in the manner shown more particularly in Figs. 5 and 6 of the drawings. The head-stock C is provided with a suitable recess, c, to fit upon the way A', a key, C', being arranged within the said recess and clamped against the way by means of screws c', to secure the head-stock firmly in position upon the said way. The tail-stock D is provided with a similar recess, d, to fit upon the way A', so that it may be longitudinally adjusted therein, and a key, D', is secured at one end by an ordinary screw, d', and at the other end by a screw, D², provided with a handle by

means of which the key D' may be readily slackened or tightened in order to permit the tail-stock to be adjusted and to be secured after adjustment. It will be observed that the way A', although located on the rear of the lathe-bed A, is inclined somewhat forward, so that the spindles which are mounted in the stocks will be in line with the center of the lathe-bed, although their supporting-way is entirely to the rear of said central line, thereby giving the lathe-bed a clear front in order to not obstruct the movements of the slide-rest.

Upon its front side the lathe-bed A is provided with a way, A², upon which the slide-rest carriage E is mounted. The lathe-bed A is cast hollow at the front, thus forming a recess, a, extending along its entire length, within which recess the usual rack and screw for feeding the slide-rest carriage are arranged, so that these parts and their co operating mechanism are effectually protected from dust and dirt and the cuttings which may fall from the work mounted in the lathe. A similar recess, a', may be formed in the under side of the lathe, so that all superfluous material in the lathe-bed is dispensed with and a light, and at the same time strong, lathe-bed produced.

The slide-rest carriage E, which is mounted, as hereinbefore described, on the front of the lathe-bed, upon the way A² thereon, is provided with the usual longitudinal feeds or feeding mechanisms—both a screw-feed by means of the screw F driven from the head stock in the usual manner, and an automatic rack-and-pinion feed driven from the said screw and capable of being converted into a hand-feed when desired. These features are well known and common in lathes of this description, and I therefore, will not describe the same here. By their means the slide-rest carriage E may be fed longitudinally upon its ways in the desired manner. Upon the carriage E is mounted a vertical slide, G, moving in suitable ways therein, and actuated by means of a feed-screw, G'. This feed-screw is journaled vertically in the slide, as shown more particularly in Fig. 2 of the drawings, and passes through a nut, e, attached to the carriage E. A bevel-pinion, g, is secured to the feed-screw G' and meshes with a corresponding bevel-pinion, g', on the inner

end of a horizontal shaft, G^2 , the end of which projects outward beyond the front surface of the slide G , and is provided either with a key-head, g^2 , to receive a suitable wrench or key for turning the same, or with a hand-wheel or lever for this purpose.

G^3 represents an indicator mounted on the front of the slide G , upon the bearing of the shaft G^2 , and consisting of a disk having suitable divisions marked upon its margin to form a scale, and g^3 represents a pointer which is secured upon the shaft G^2 to co-operate with the said indicator-disk, upon the graduated margin of which its extremity rests. The pointer g^3 has a split or divided hub surrounding the shaft G^2 and connected by a clamp-screw, g^4 , so that the said pointer may be adjusted around the shaft G^2 and clamped thereon after adjustment. By this means the precise height to which the slide G is raised by means of the feed screw G' may be easily read upon the indicator-disk G^3 , and when it is desired to move the said slide upward or downward a fixed distance from the position which it occupies the pointer g^3 may be readily adjusted around the shaft G^2 , so as to point to the zero-mark on the indicator-disk, and then secured upon its shaft. The desired movement may then be given to the slide G , and the extent thereof may be accurately read by means of the indicator.

H represents a revolving head mounted upon the top of the slide G , the connection being shown in the present instance as effected by means of a frusto conical hub, h , extending downward through a suitable recess of corresponding shape in the top G^4 of the slide G , and having a threaded extremity, h' , on the under side of said top G^4 , upon which is mounted a clamping-nut, H' . The head G^4 of the slide G is semicircular in shape at the front to correspond with the shape of the front portion of the head H , which is graduated, as shown, to indicate the precise angular position of the head, an index-mark being placed upon the head G^4 for this purpose at the center of its front margin. It will thus be seen that the head H may be adjusted to any desired angle in relation to the slide G , and may be secured after adjustment by tightening the clamping-nut H' in an obvious manner.

In suitable ways in the head H is mounted a table, I , provided on its upper surface with suitable T-grooves to receive either a tool-post, in case the table be employed to carry the tool, or a vice to hold the work, in case the table be employed to carry the work. In this latter case the work may also be bolted directly upon the face of the table, if necessary or desirable. The table I is given a cross-feed by means of a feed-screw, I' , journaled in a suitable bearing, i , in the table I , and provided at its outer end with a hand-wheel, by means of which it may be revolved. The said feed-screw I' extends through a suitably-threaded aperture, i^2 , in the head H , or a fixed nut in said head may be substituted therefor. By this means a cross-feed

may be imparted by hand to the table I . In order, however, to provide for the said table a power cross-feed which shall be operative at any angle of its adjustment, and which may readily be thrown in or out of gear, as desired, I have devised the following construction:

J indicates a bevel-pinion, mounted to revolve in a suitable recess in the head H , and held from longitudinal movement therein, the said bevel-pinion being splined upon the feed-screw I' , so as to rotate with the latter, but not to move longitudinally therewith. This pinion meshes with a corresponding bevel-pinion, j , on the upper end of a shaft, J' , which latter shaft has its axis coincident with the axis of revolution of the head H , and which derives its motion from the main feed-screw F through suitable connecting mechanism. In the construction shown the shaft J' extends downward vertically through the hub h and its screw-threaded extension h' , and also through suitable bearings in the slide G , in all of which it is vertically movable, its lower end resting upon an adjusting-cam, j' , upon a short cross-shaft, J^2 , provided at its outer extremity with a handle, j^2 , by means of which said shaft and cam may be rotated to raise or lower the said shaft J' , and thereby throw its pinion j into or out of gear with the pinion J . Upon the shaft J' is mounted a pinion, j^3 , which meshes with an elongated pinion, k , upon a short vertical shaft, K , mounted in suitable bearings in the carriage E . The shaft K is also provided with a bevel-pinion, k' , which meshes with a corresponding bevel-pinion, l , on a shaft, L , also mounted in the carriage E , and provided at its inner end with a worm-wheel, L' , with which a worm, L^2 , splined on the main feed-screw F , engages. It will thus be seen that when the shaft J' is moved upward to cause its pinion j to mesh with the pinion J on the feed-screw I' , movement will be transmitted from the main feed-screw F to the said feed-screw I' , and will thereby automatically feed the table I across the lathe-bed. It will also be seen that since the axis of the shaft J is coincident with the center of revolution of the head H , the said head and the table I , mounted thereon, may be turned to any desired angle without in any way affecting the operation of the automatic cross-feed. This automatic feed may also be thrown out of gear, when desired, by simply lowering the shaft J through the medium of the mechanism described for that purpose.

In order to provide an efficient bearing and support for the tail spindle of the lathe, I construct the tail-stock bearing in the following manner. The spindle M is mounted in the bearing N on the tail-stock D in the usual manner, but the said bearing is divided along the plane of the axis, as shown at n , for quite a distance from the end thereof, and is further divided circumferentially at right angles to the former line of division, as shown at n' , this second cut being carried half-way round the bearing. The split bearing thus formed

is provided at each end with opposite lugs, O and O', through which pass adjusting-screws o, by means of which the said split bearing may be tightened at both ends, or, in other words, adjusted to take up any wear which may occur. Between these adjusting-screws is located a clamping screw, P, by means of which the bearing may be readily clamped and unclamped to permit adjustment of the tail-spindle in the usual manner.

The operation of my improved lathe will be readily understood from the preceding description, and therefore needs no detailed explanation. It will be seen that I provide a lathe having a light and strong bed, which will effectually protect the feed mechanism from dirt and cuttings, and will give to the carriage a free and unobstructed movement from end to end. It will also be seen that the vertical adjustment of the tool or work holding table may be accurately determined by means of the indicator provided for that purpose, and that an automatic cross-feed at any desired horizontal angle may be given to the said table.

Various modifications in the details of construction may be made without departing from the principle of my invention, and I therefore do not wish to be understood as limiting myself strictly to the precise details hereinbefore described, and shown in the drawings.

Having thus described my invention, what I claim as new, and desire to secure by Letters Patent, is—

1. In a lathe, the lathe-bed A, provided with the way A' on its rear side to receive the head and tail stocks, with the way A² on its front side to receive the slide-rest carriage, and having the recess a, open at the front only, to receive the feed mechanism, substantially as and for the purposes specified.

2. In a lathe, the combination, with the carriage and the vertical slide thereon, of the mechanism for adjusting said slide, the shaft for operating said mechanism, a pointer adjustably mounted on said shaft, and a fixed and suitably-graduated indicator-disk, substantially as and for the purposes specified.

3. In a lathe, the combination, with the carriage E and vertical slide G, of the adjusting-screw G', having pinion g, the operating-shaft G², having pinion g' to mesh therewith, the pointer g³, adjustably mounted on said shaft, and the fixed indicator-disk G³, substantially as and for the purposes specified.

4. In a lathe, the combination, with the carriage and its power-feed screw, of the rotary head mounted on said carriage, the table mounted on suitable ways on said head and

adjustable to any desired horizontal angle, and mechanism driven from the main feed-screw for automatically feeding said table at any angle of its adjustment, substantially as and for the purposes specified.

5. In a lathe, the combination, with the carriage and its feed-screw, of the head mounted thereon and adjustable around a vertical axis, the table mounted in suitable ways on said head and provided with a feed-screw, whereby it may be fed across the lathe-bed at any desired angle, and connecting mechanism between the main feed-screw and table feed-screw, whereby an automatic power feed at any desired angle is imparted to the table, substantially as and for the purposes specified.

6. In a lathe, the combination, with the carriage, the vertical slide thereon, the rotary head on said slide, and the table mounted in suitable ways on said head and provided with a feed-screw, of a pinion splined on said feed-screw, and a shaft having its axis coincident with that of the rotary head, provided with a pinion to mesh with the splined pinion and connected with the main feed-screw by suitable connecting-gearing, substantially as and for the purposes specified.

7. In a lathe, the combination, with the carriage E, the slide G thereon, the rotary head H, and the table I, having adjusting-screw I' and bevel-pinion J, of the shaft J', having pinion j, suitably connected to the main feed-screw and longitudinally adjustable to throw the said pinions into and out of gear, substantially as and for the purposes specified.

8. In a lathe, the combination, with the carriage E, feed-screw F, slide G, rotary head H, and table I, having feed-screw I' and splined pinion J, of the shaft J', having pinion j, and longitudinally adjustable by means of a suitable cam, j', the pinion j² on said shaft, the shaft K, mounted in the carriage and having elongated pinion k and bevel-pinion k', and the shaft L, having bevel-pinion l to mesh therewith, and worm-wheel L' to mesh with the feed-screw F, substantially as and for the purposes specified.

9. In a lathe, the tail-spindle M, in combination with the bearing N, split along the plane of its axis at n from its inner end for a portion of its length, and partially divided at n', circumferentially at right angles to the split n, and clamping-screws for causing the split portion to accurately clamp the spindles, substantially as and for the purposes specified.

SAMUEL SLAYTON.

Witnesses:

IRVINE MILLER,
C. FEIGEL.